

Semi-Micro Analytical Balance

MODEL: MA-50D

Dual Scale 50 / 220 g - 0.01 / 0.1 mg

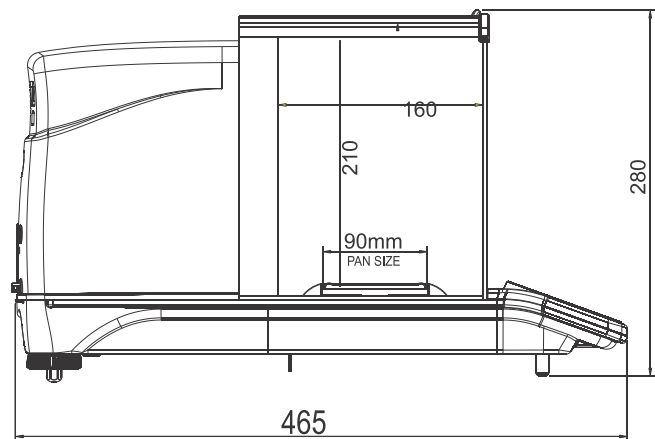

FEATURES HIGHLIGHTS:

- Electro Magnetic Force Compensation
- Statistic Weighting
- Animal Weighting
- White Black Light LCD Display
- Percentage Weighting
- Multiple Weighing Units
- RS232C Interface
- Counting Weighting Mode
- Temperature
- Under-hook Weighting
- Calibration with Internal weight
- Time
- Date

```

ID      12345
2016/10/28 12:03
-----
001+0100.0000 g
002+0100.0000 g
003+0100.0000 g
004+0100.0000 g
005+0100.0000 g
-----
N       005
AVR +0500.0000 g
S       0000.000 g
MAX +0100.0000 g
MIN +0100.0000 g
DIF    0000.0000 g
-----
    
```

STANDARD

ACCESSORIES:

- Pan
- Pan support
- Draft Ring
- Power Cord
- User manual

Print Out format

Semi-Micro Analytical Balance

MODEL: MA-50D

SPECIFICATIONS:

Model	MA-50D
Make	Galaxy
Max. (Capacity)	50 / 220g
Readability (d)	0.00001 / 0.0001g
Repeatability (±)	0.02 / 0.2mg
Linearity (±)	0.04 mg / 0.4 mg
Minimum Load	1mg / 10mg
Verification Scale Intervals (e)	1mg
Calibration	Motorized Internal Calibration
Class	Class I
Display	LCD with black light
Response Time	4-6 Sec
Pan size (mm)	90mm Ø
Tara Range	Full
Operating Temperature	+ 15°C to + 30°C
Sensitivity Drift ±	2 ppm / °C
Density	Function Available
Data Output mode selection	Command & Continuous Output
Key sound	Yes
Weighing Chamber Height	210 mm
Unit	g , oz ,ct, lb , ozt , dwt, GN
Application Mode	PCS, %, Weighting, Animal Weighing, Check Weighing, Density, Statistics Weighing
Baud rate options	1200, 2400, 4800, 9600
Interface	RS232C
Power supply	AC 220V/50-60 Hz
Dimension (L x W x H) mm	580x385x480
Weight	13kg